

Lighting Retrofits

The low hanging fruit
or is it?

Kentucky Electric Cooperative's 2006
Key Accounts Technical Conference

Low hanging fruit because:

- Savings are real and predictable
- Retrofits are as good or better than the original
- Fast paybacks

Assumptions for cost benefit analysis

- \$5.50 per kW demand charge and 4¢/kWh energy charge.
- 136 hours per week of operation
- \$50 to \$75 per fixture labor charge to retrofit

Reference fixture 400 W metal halide



The problem with standard 400 W Metal Halide lamps

- They are no more efficient than a high output fluorescent lamp
- When the voltage sags they go out and may require up to 20 min. to restrike
- Color rendition (CRI) is OK – on the order of 65, incandescent is 100
- They lose light output relatively fast
(Costs \$162.65 per year to run)

Lumen Depreciation

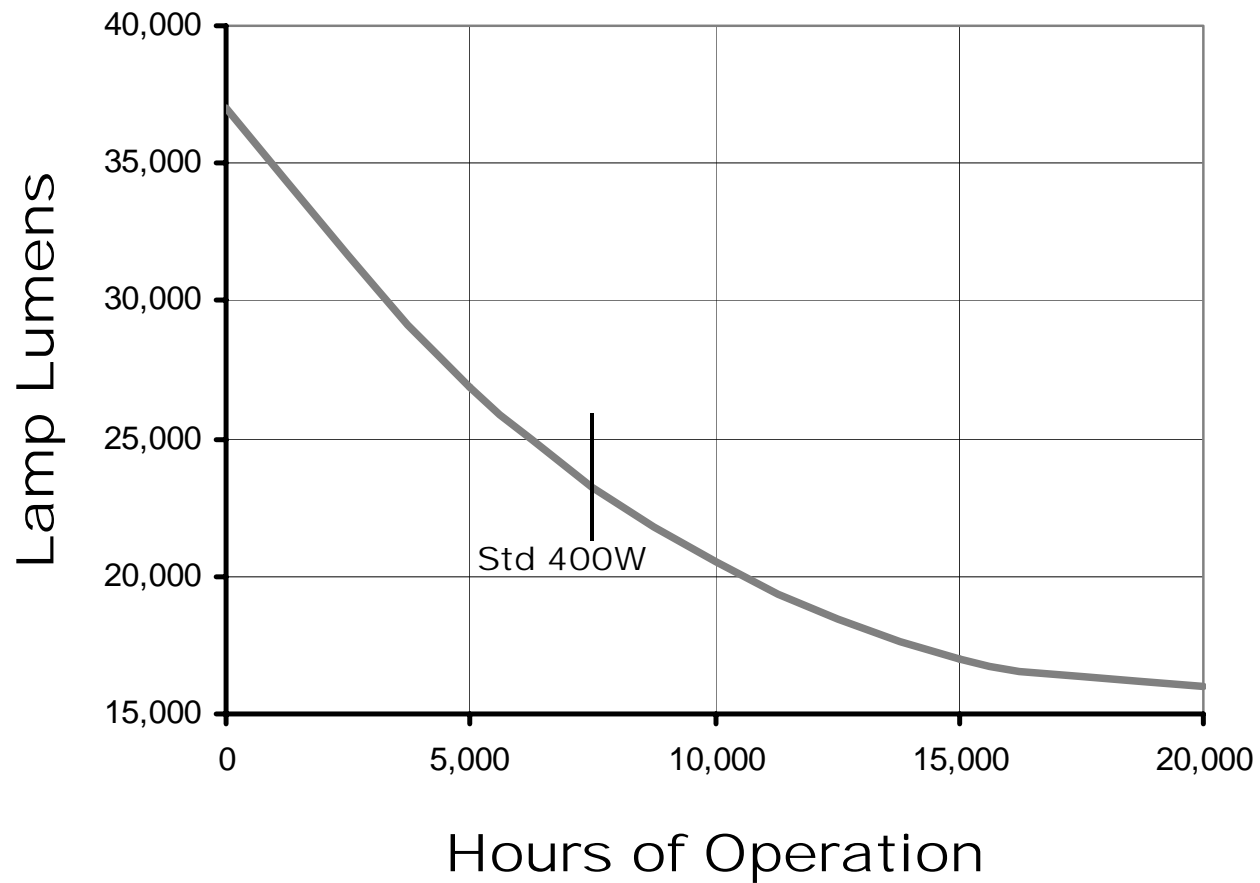

Lumen Depreciation

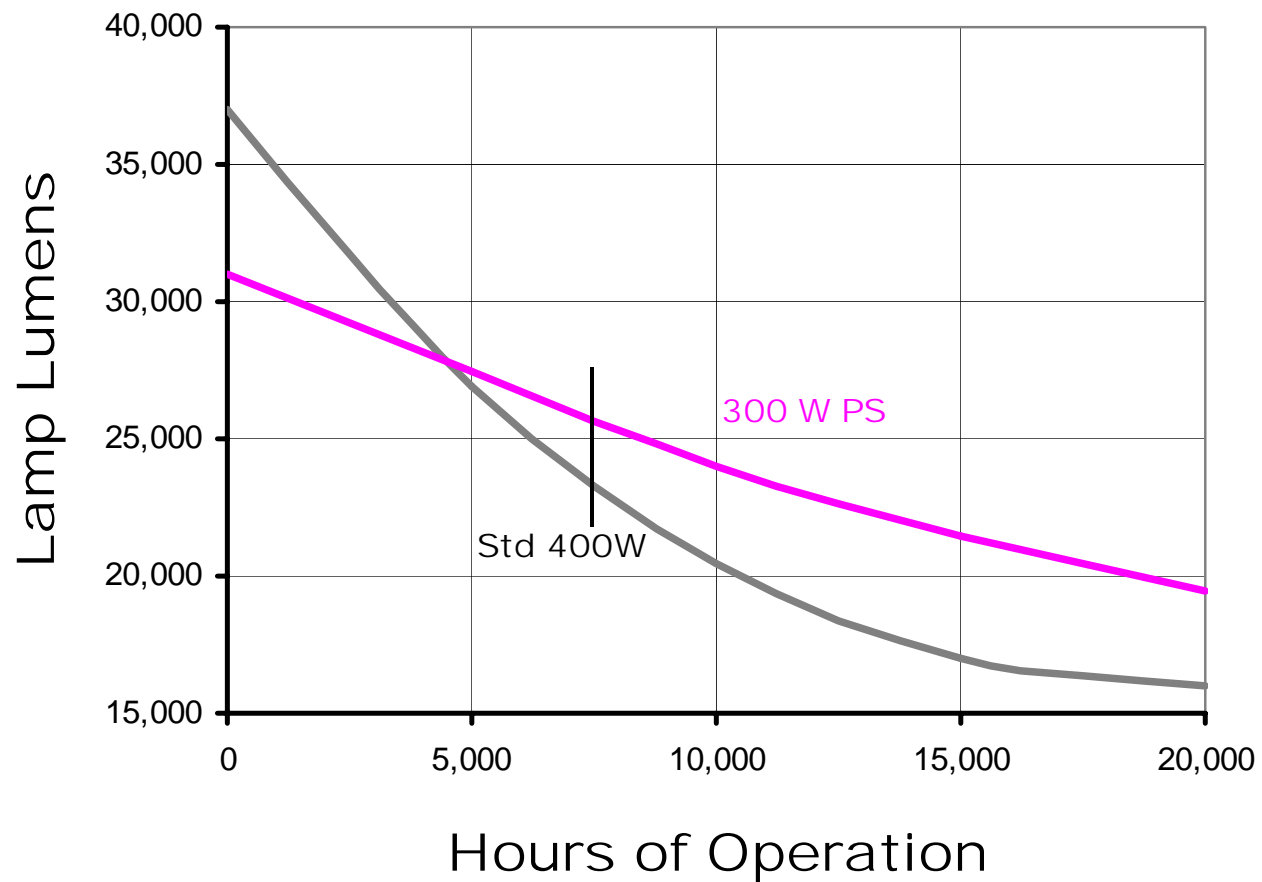

Simplest option

Pulse start Metal Halide, 300 W or 340 W

+ Equivalent to 400 W and easy to retrofit

+ One lamp per fixture to maintain

+ Quicker restrike

- Higher wattage than other options

(\$42 annual savings, \$50 to retrofit, \$95 to purchase – 42 month payback)

Lumen Depreciation II

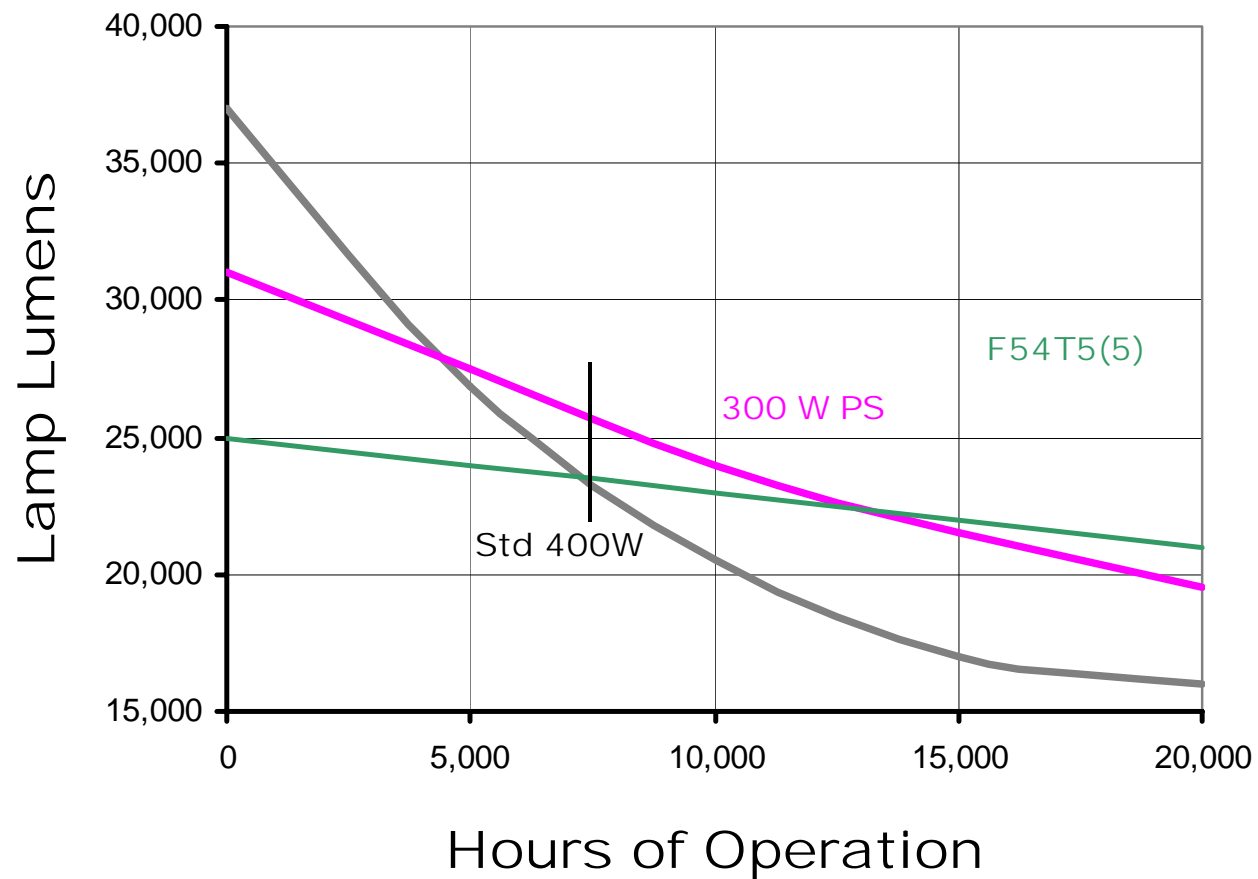

Retrofit fixtures with fluorescent lamps in them

- Advantages
 - Very low wattage
 - Excellent CRI
 - Easy to install
 - Don't suffer from restrike delay
 - Can easily be used with controls
 - May be able to lower illumination level
- Disadvantages
 - 4 to 8 lamps per fixture
 - May not produce the illumination advertised

Many Fluorescent Options

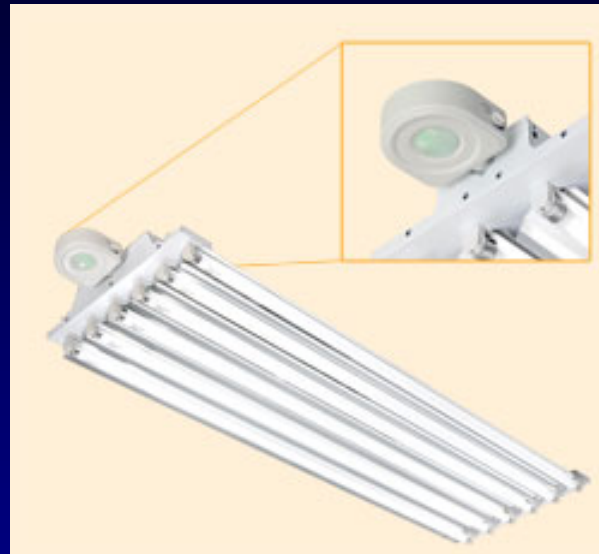

Kentucky Electric Cooperative's 2006
Key Accounts Technical Conference

Lighting types compared

All options have 50 fixtures

- Current A – 400 W MH
- Option B – 300 W MH PS
- Option C – F54T5/HO – 4-lamps
- Option D – F32T8, HO ballast – 4-lamps
- Option E – F54T5/HO – 6-lamps

Input Watts/Fixture

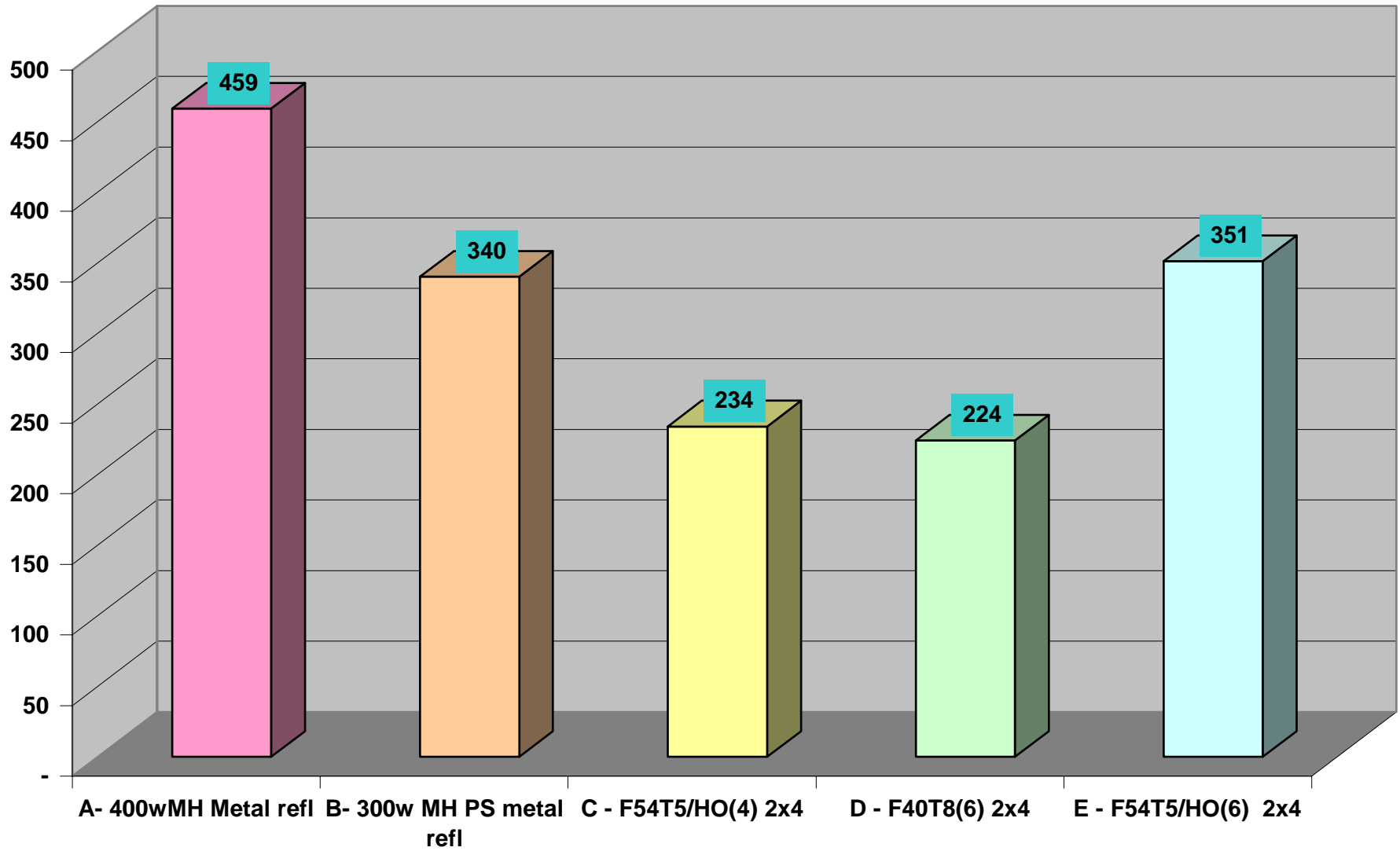

Illumination (fc)

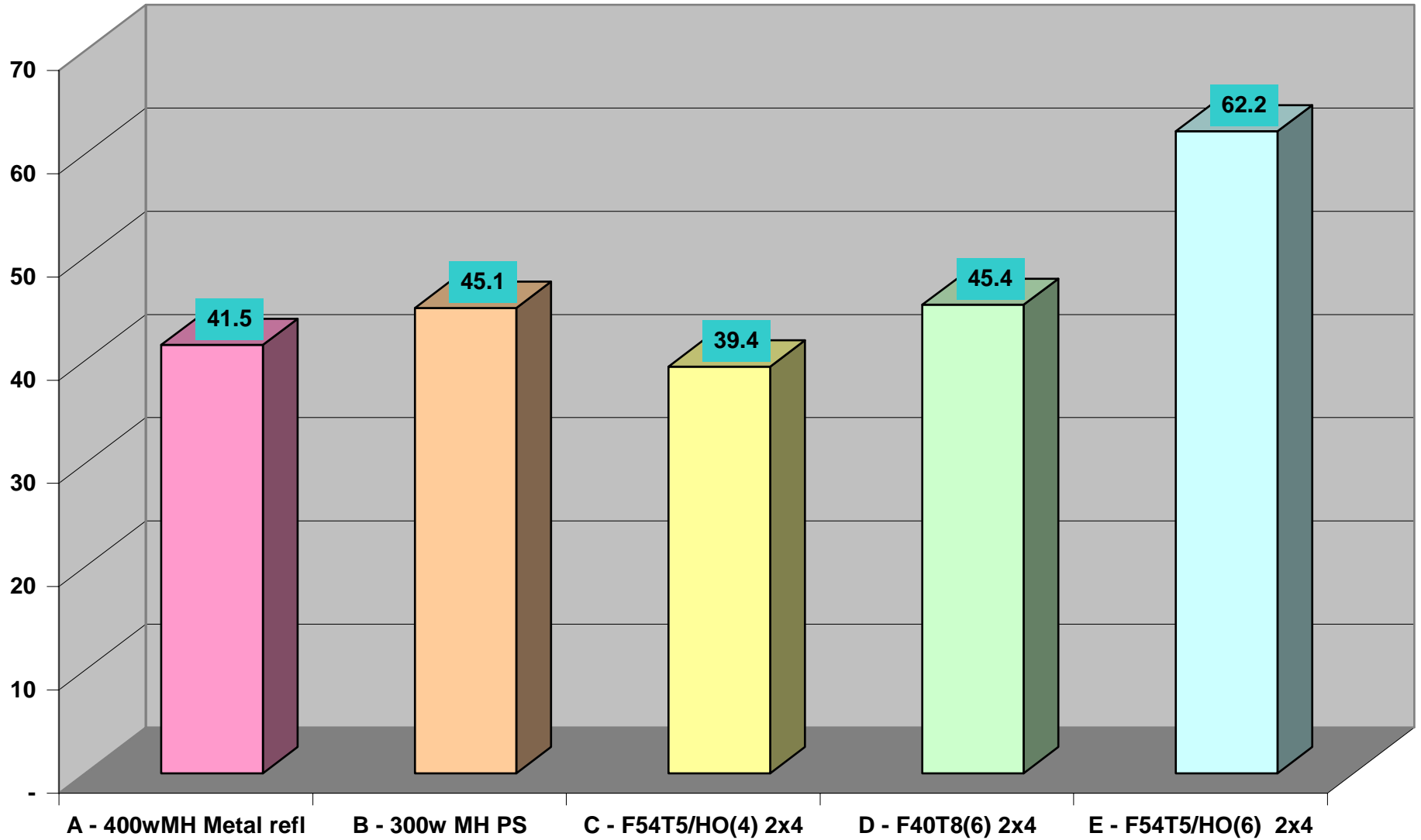

Payback

Payback (Years)	B - 300w MH PS	C - F54T5/HO(4)	D - F40T8(6)	E - F54T5/HO(6)
w/ maintenance	3.55	3.34	2.52	9.09
w/o maintenance	3.49	3.25	2.68	7.34

Replacement lamps	18	47	88	70
-------------------	----	----	----	----

Kentucky Electric Cooperative's 2006
Key Accounts Technical Conference

Some Manufactures May be Using Snake Oil to Push Their Product

- Not comparing similar fixtures
- Using color to promote better seeability with lower illumination

Fixtures with glass reflectors



Light level reduced
from 41.5 fc to 31.8

Kentucky Electric Cooperative's 2006
Key Accounts Technical Conference

Is this real? Scoptic sight



**4000k MVR Metal Halide
85 Design Lumens/Watt
107 Pupil Lumens/Watt**



**UltraLux™ High Bay
w/BlueMax™
88 Design Lumens/Watt
202 Pupil Lumens/Watt**

Questions

Kentucky Electric Cooperative's 2006
Key Accounts Technical Conference